

# FIM

## INNOVATOR 716 PLOW PARTS CATALOG





## TO THE CUSTOMER

The part numbers in this catalog were correct at the time of publication. However, due to our efforts to continuously improve our products, some parts numbers may have changed after publication. When placing an order for parts, please verify the part numbers with your dealer.

## BOLT & CAP SCREW STRENGTH IDENTIFICATION

Bolts and cap screws required to have high-strength qualities equivalent to metric property class 10.9 (SAE grade 8) or higher are identified throughout this catalog by the description "Grade 8". All standard bolts and caps are metric property class 8.8 (SAE grade 5) or lower.

## ILLUSTRATIONS

Illustrations in this catalog are only intended as a reference for dealers and customers. These illustrations do not necessarily represent the exact view of the part.



# INNOVATOR 716 PLOW

## PARTS CATALOG



## TABLE OF CONTENTS

---

Overview . . . . .	2
A-Frame . . . . .	3
Boom . . . . .	4
Boom Extension . . . . .	5
Hydraulics . . . . .	6
Front Gauge Wheel . . . . .	7
Rear Gauge Wheel . . . . .	8
Plow Bottom 1-4 . . . . .	9
Plow Bottom 5-6 . . . . .	10
Plow Bottom 7 . . . . .	11
Safety Trip . . . . .	12
Complete Parts List . . . . .	13

# OVERVIEW

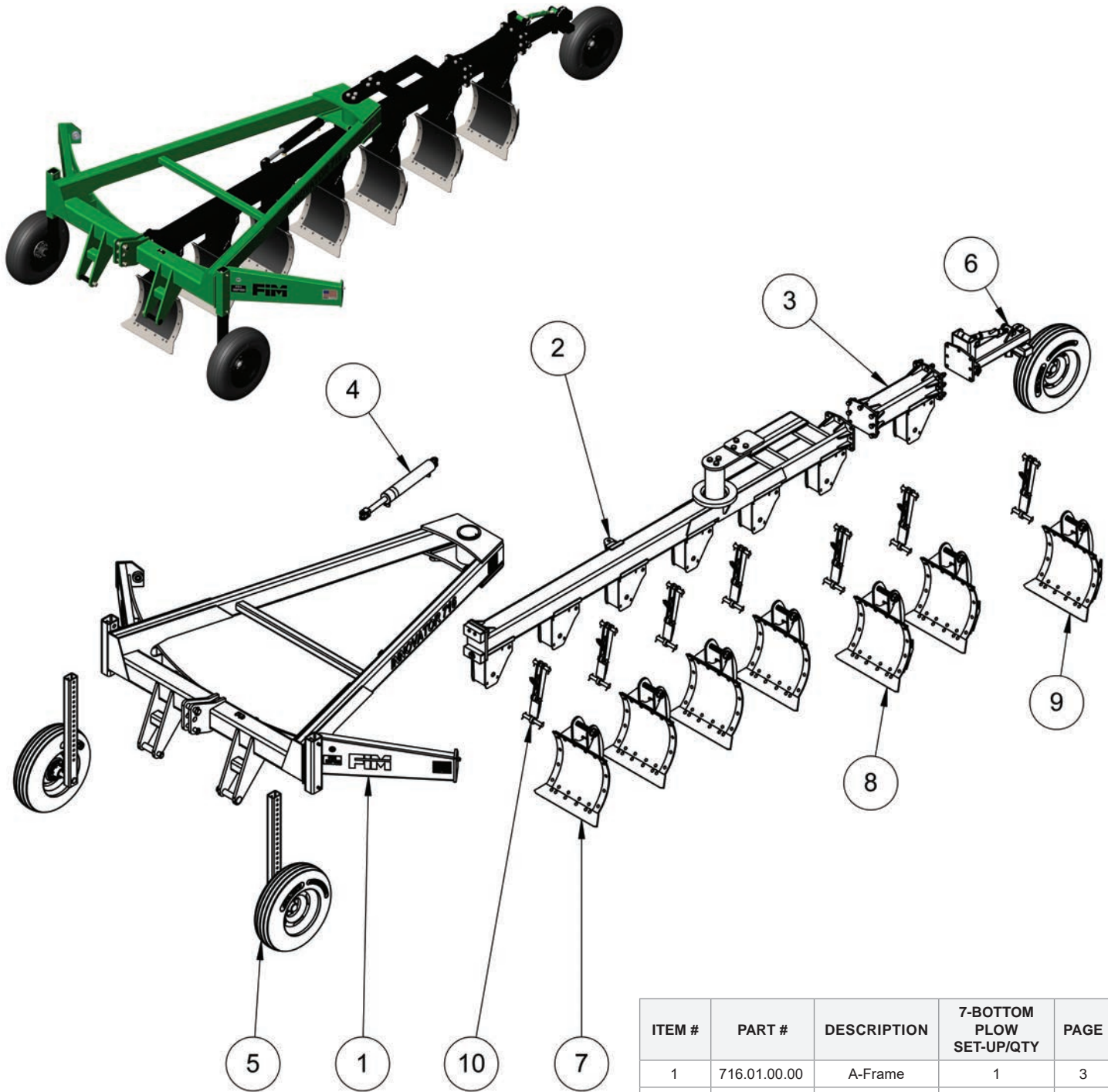

ITEM #	PART #	DESCRIPTION	7-BOTTOM PLOW SET-UP/QTY	PAGE
1	716.01.00.00	A-Frame	1	3
2	716.02.00.00	Boom	1	4
3	716.03.00.00	7 <sup>th</sup> Bottom Boom Extension	1	5
4	716.04.00.00	Hydraulics	1	6
5	716.05.00.00	Front Gauge Wheel	2	7
6	716.06.00.00	Rear Gauge Wheel	1	8
7	716.07.00.00	Plow Bottom 1-4	4	9
8	716.08.00.00	Plow Bottom 5-6	2	10
9	716.09.00.00	Plow Bottom 7	1	11
10	716.10.00.00	Safety Trip	7	12

# A-FRAME

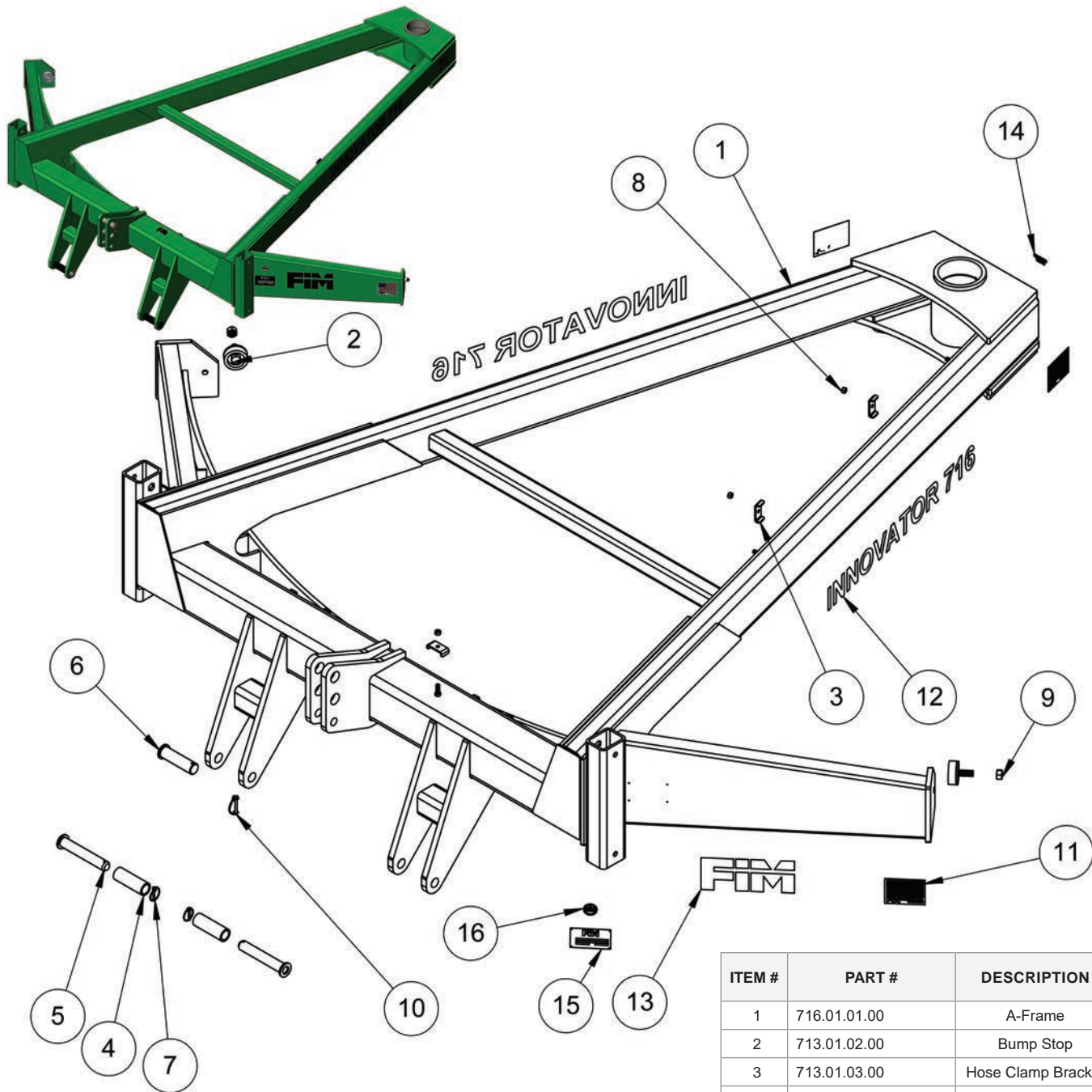

ITEM #	PART #	DESCRIPTION	QTY
1	716.01.01.00	A-Frame	1
2	713.01.02.00	Bump Stop	2
3	713.01.03.00	Hose Clamp Bracket	3
4	713.01.04.00	Cat. 4 Conversion Bushing	2
5	716.01.05.00	Cat. 3 Hitch Pin	2
6	716.01.07.00	Cat. 4 Top Link Pin	1
7	1.75_Lynch_Pin	Lynch Pin (1 3/4")	3
8	N12	Hex Nut (1/2")	3
9	NN34	Nylon Lock Nut (3/4")	2
10	Round Locking Pin	Round Locking Pin	1
11	FIM_USA_Sticker	FIM USA Sticker	4
12	Innovator_716_Sticker	Innovator 716 Sticker	2
13	FIM_716_Sticker	FIM Logo Sticker	2
14	Grease_Sticker	Grease Daily Sticker	1
15	FIM_SN_Plate	Serial Number Plate	1
16	FIM_QC_Sticker	FIM Quality Control Sticker	1

# BOOM

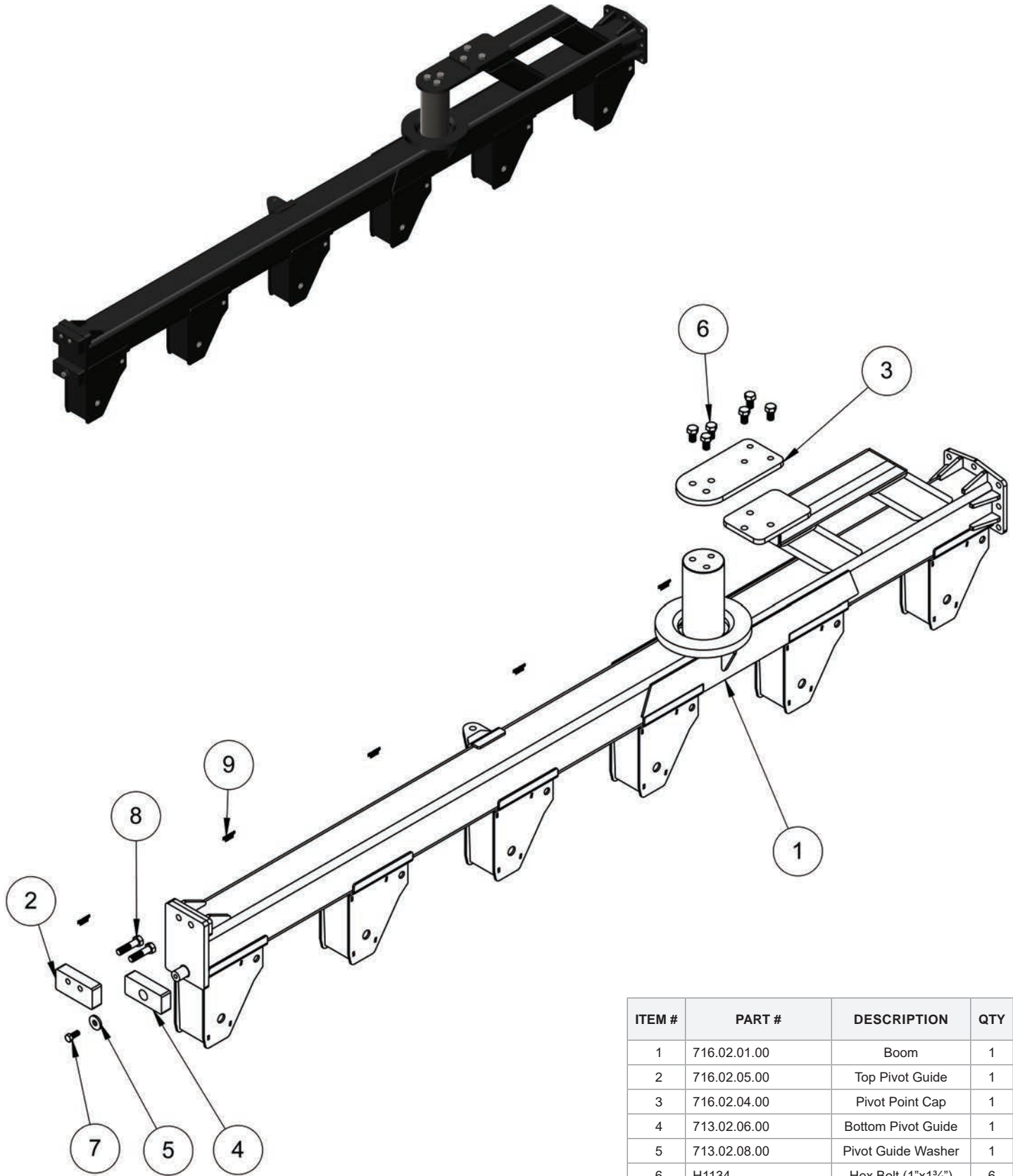

ITEM #	PART #	DESCRIPTION	QTY
1	716.02.01.00	Boom	1
2	716.02.05.00	Top Pivot Guide	1
3	716.02.04.00	Pivot Point Cap	1
4	713.02.06.00	Bottom Pivot Guide	1
5	713.02.08.00	Pivot Guide Washer	1
6	H1134	Hex Bolt (1"x1¼")	6
7	H34134	Hex Bolt (¾"x1¼")	1
8	H14	Hex Bolt (1"x4")	2
9	Grease_Sticker	Grease Daily Sticker	6

# BOOM EXTENSION

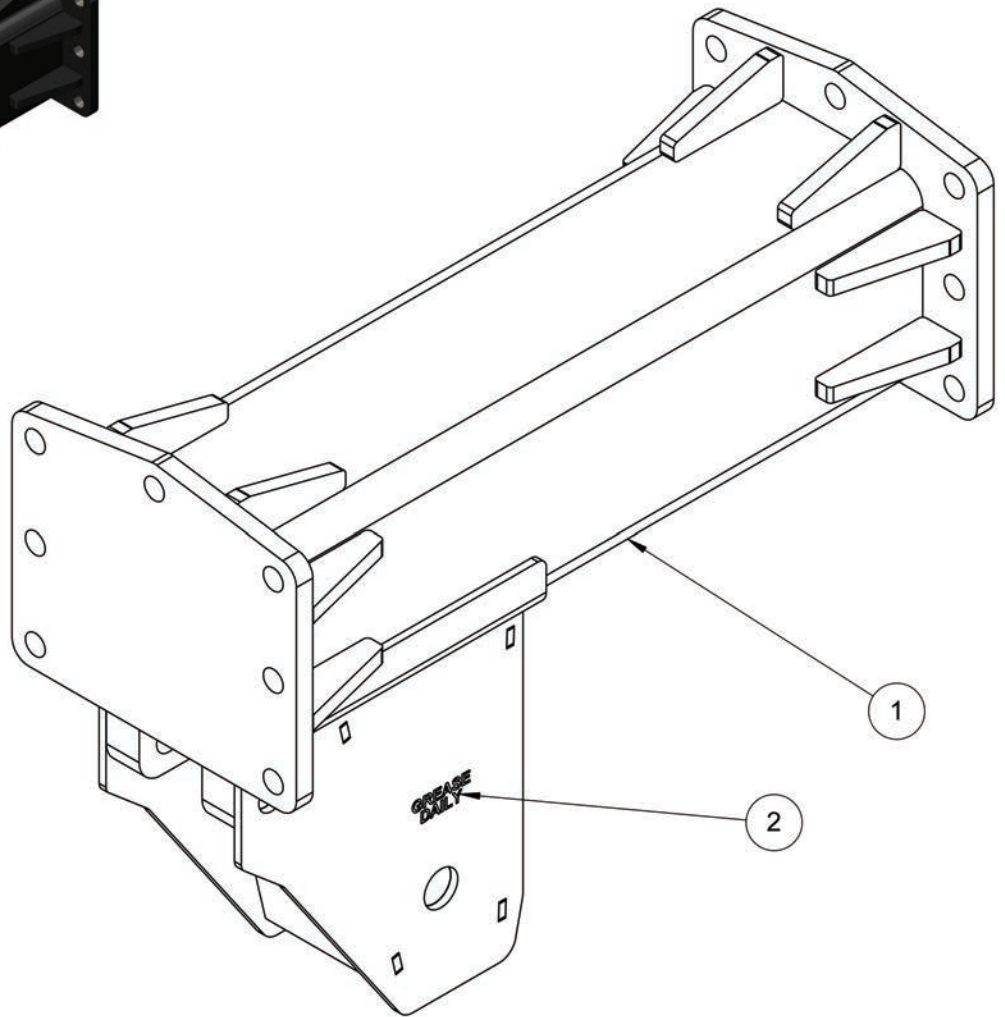

## DOUBLE BOOM EXTENSION (OPTIONAL)

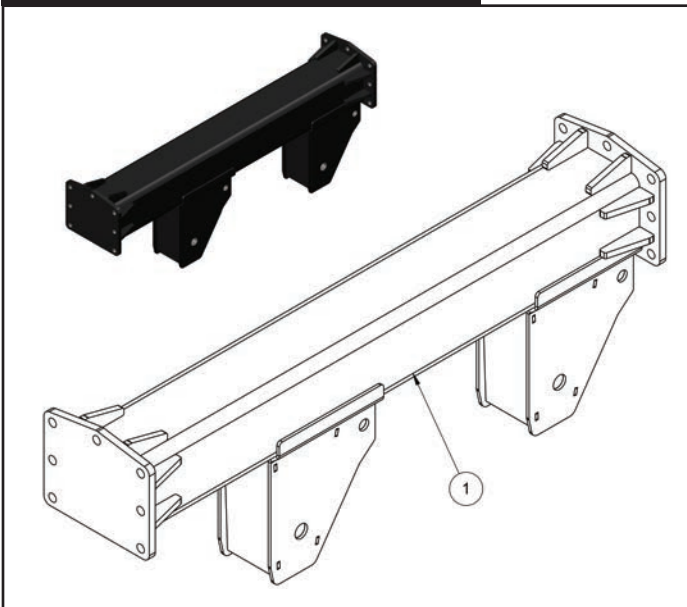

ITEM #	PART #	DESCRIPTION	QTY
1	713.03.00.00	7 <sup>th</sup> Bottom Boom Extension	1
2	Grease_Sticker	Grease Daily Sticker	1
3	820.03.00.00	7 <sup>th</sup> & 8 <sup>th</sup> Bottom Boom Extension (Optional)	1

# HYDRAULICS

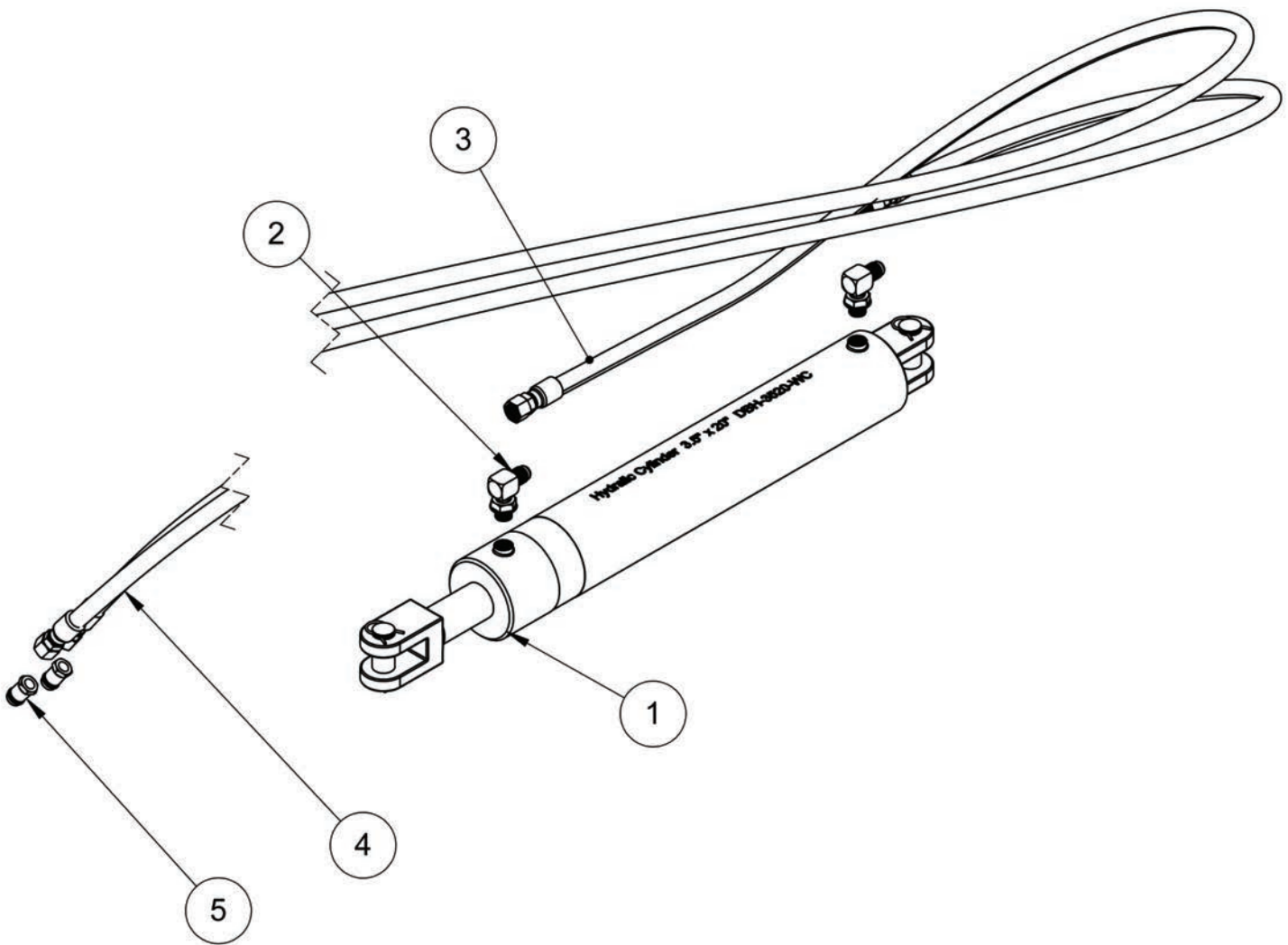

ITEM #	PART #	DESCRIPTION	QTY
1	DBH-3520-WC	Plow Hydraulic Cylinder	1
2	8MB-9MJ90	Hydraulic Cylinder Adapter	2
3	713.04.04.00	Hydraulic Hose (240")	1
4	713.04.05.00	Hydraulic Hose (220")	1
5	8010-4	Hydraulic Tractor Coupler	2



# FRONT GAUGE WHEEL

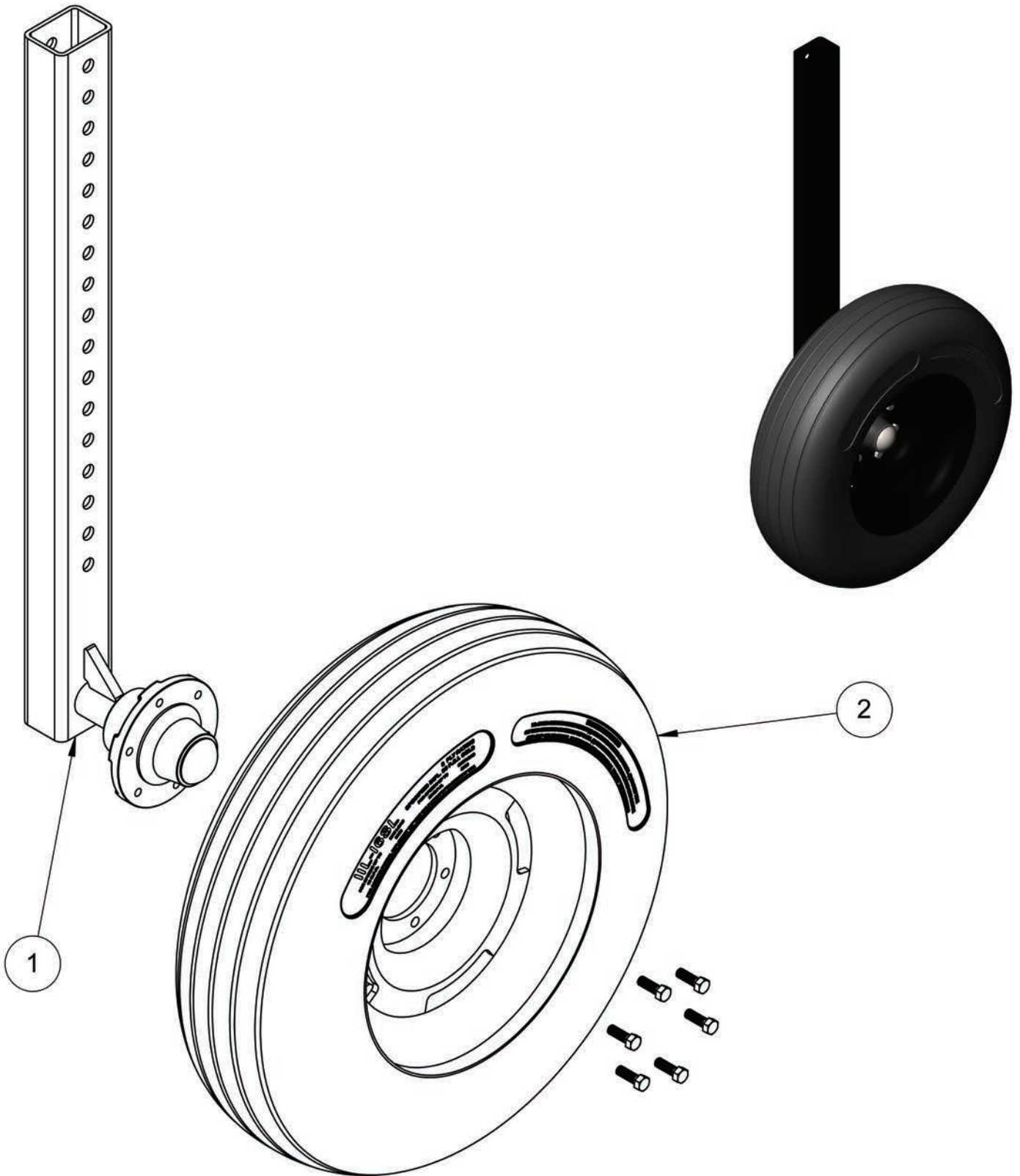

ITEM #	PART #	DESCRIPTION	QTY
1	716.05.01.00	Front Gauge Wheel	2
2	16081	Mtd Wheel & Tire	2

# REAR GAUGE WHEEL

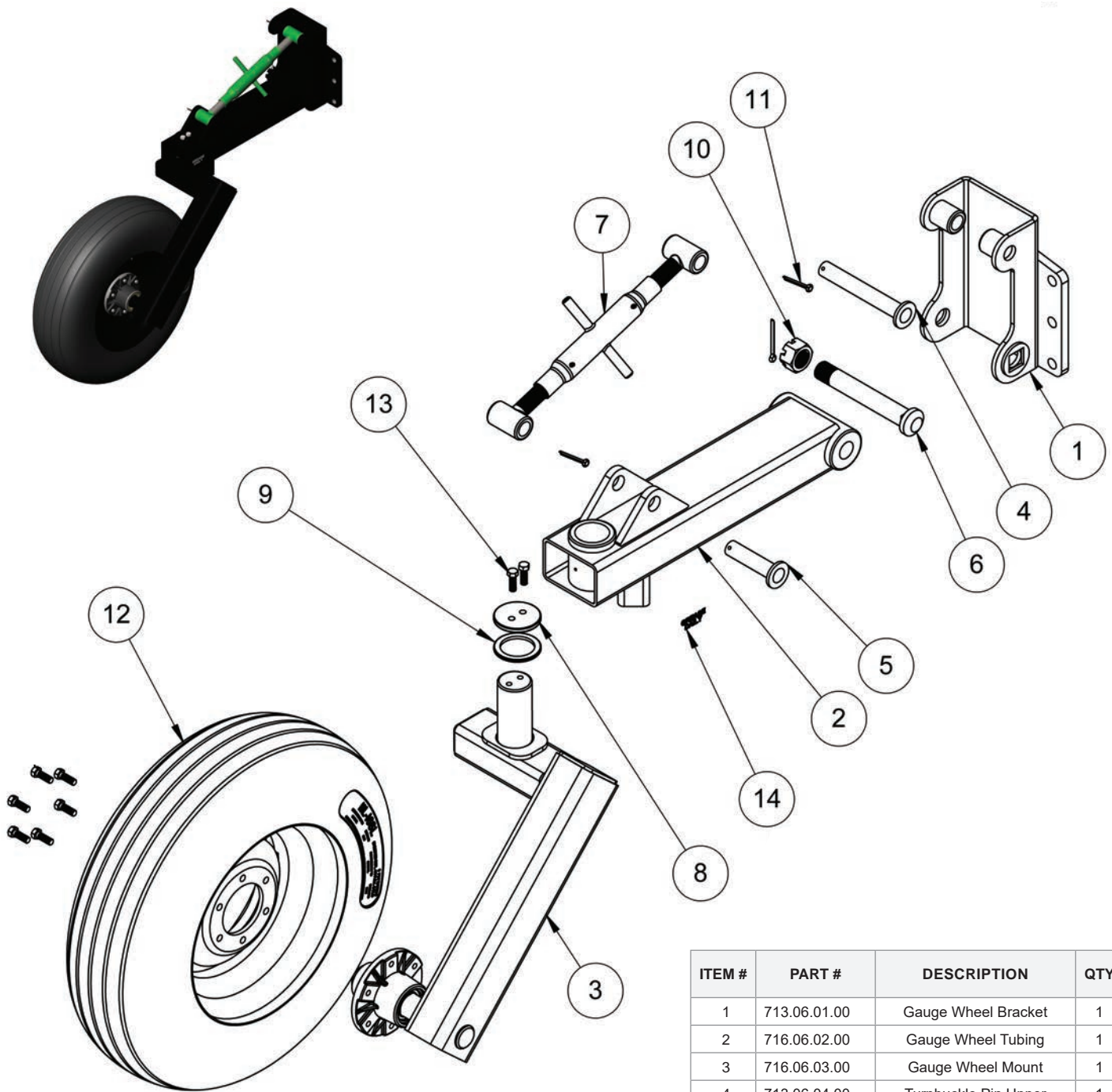

ITEM #	PART #	DESCRIPTION	QTY
1	713.06.01.00	Gauge Wheel Bracket	1
2	716.06.02.00	Gauge Wheel Tubing	1
3	716.06.03.00	Gauge Wheel Mount	1
4	713.06.04.00	Turnbuckle Pin Upper	1
5	713.06.05.00	Turnbuckle Pin Lower	1
6	713.06.06.00	Gauge Wheel Bracket Bolt	1
7	713.06.07.00	Turnbuckle	1
8	716.06.03.02	Pivot Point Cap	1
9	716.06.03.03	Pivot Washer	1
10	SN112	Slotted Nut (1½")	1
11	CP14X3	Cotter Pin (¼"x3")	3
12	16081	Mtd Wheel & Tire	1
13	H12112	Hex Bolt (½"x1½")	2
14	Grease_Sticker	Grease Daily Sticker	1

# PLOW BOTTOM 1-4

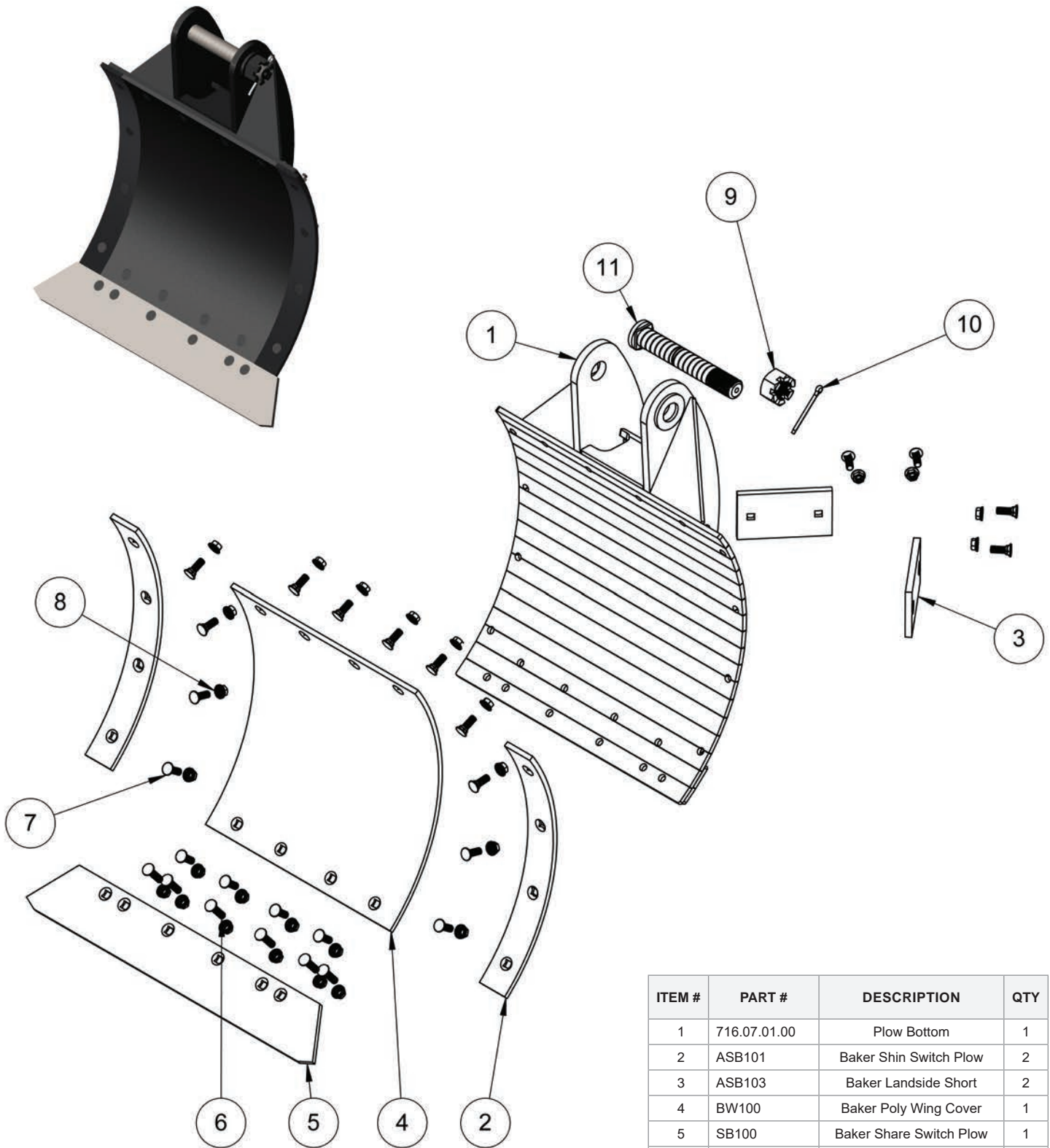

ITEM #	PART #	DESCRIPTION	QTY
1	716.07.01.00	Plow Bottom	1
2	ASB101	Baker Shin Switch Plow	2
3	ASB103	Baker Landside Short	2
4	BW100	Baker Poly Wing Cover	1
5	SB100	Baker Share Switch Plow	1
6	P122	Plow Bolt (1/2"x2")	6
7	P12112	Plow Bolt (1/2"x1 1/2")	20
8	FN12	Flange Nut (1/2")	26
9	SN112	Slotted Nut (1 1/2")	1
10	CP14X3	Cotter Pin (1/4"x3")	1
11	716.07.02.00	Bottom Pivot Bolt	1

# PLOW BOTTOM 5-6

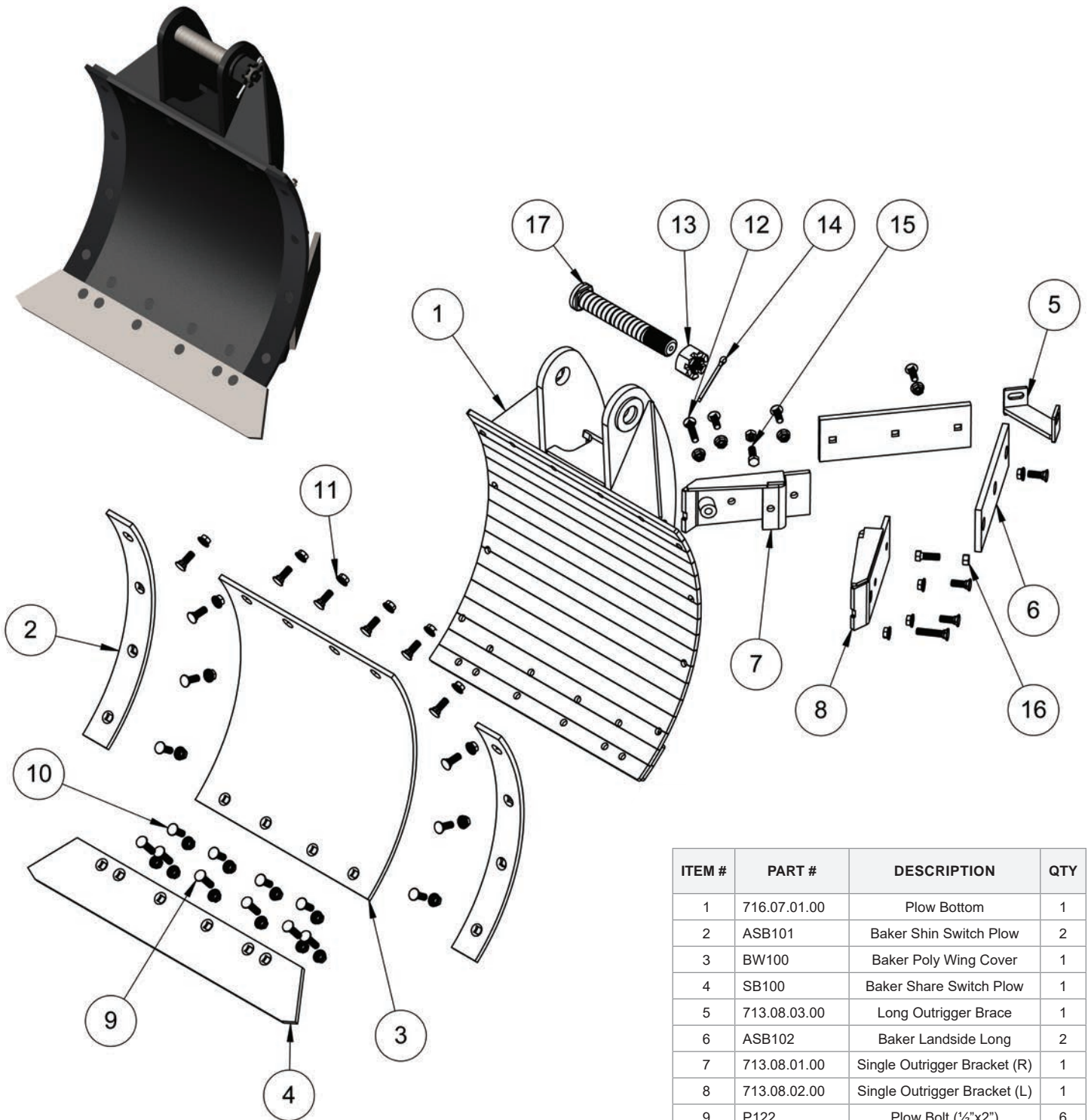

ITEM #	PART #	DESCRIPTION	QTY
1	716.07.01.00	Plow Bottom	1
2	ASB101	Baker Shin Switch Plow	2
3	BW100	Baker Poly Wing Cover	1
4	SB100	Baker Share Switch Plow	1
5	713.08.03.00	Long Outrigger Brace	1
6	ASB102	Baker Landside Long	2
7	713.08.01.00	Single Outrigger Bracket (R)	1
8	713.08.02.00	Single Outrigger Bracket (L)	1
9	P122	Plow Bolt (1/2"x2")	6
10	P12112	Plow Bolt (1/2"x1 1/2")	22
11	FN12	Flange Nut (1/2")	30
12	P12212	Plow Bolt (1/2"x2 1/2")	2
13	SN112	Slotted Nut (1 1/2")	1
14	CP14X3	Cotter Pin (1/4"x3")	1
15	H12112	Hex Bolt (1/2"x1 1/2")	2
16	N12	Hex Nut (1/2")	2
17	716.07.02.00	Bottom Pivot Bolt	1

# PLOW BOTTOM 7

32 2024-01-15 12:00:00 AM

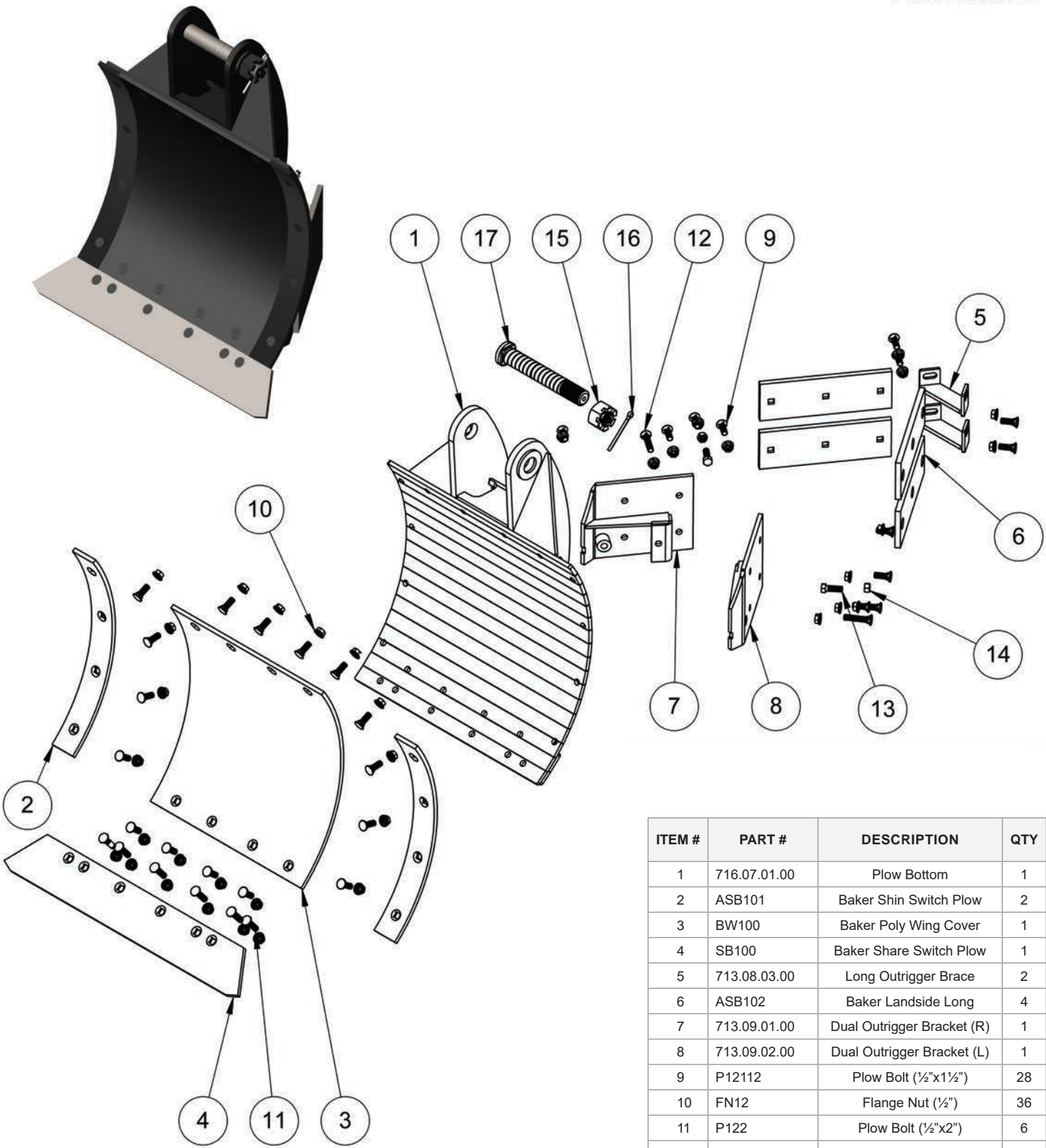

ITEM #	PART #	DESCRIPTION	QTY
1	716.07.01.00	Plow Bottom	1
2	ASB101	Baker Shin Switch Plow	2
3	BW100	Baker Poly Wing Cover	1
4	SB100	Baker Share Switch Plow	1
5	713.08.03.00	Long Outrigger Brace	2
6	ASB102	Baker Landside Long	4
7	713.09.01.00	Dual Outrigger Bracket (R)	1
8	713.09.02.00	Dual Outrigger Bracket (L)	1
9	P12112	Plow Bolt (1/2"x1 1/2")	28
10	FN12	Flange Nut (1/2")	36
11	P122	Plow Bolt (1/2"x2")	6
12	P12212	Plow Bolt (1/2"x2 1/2")	2
13	H12112	Hex Bolt (1/2"x1 1/2")	2
14	N12	Hex Nut (1/2")	2
15	SN112	Slotted Nut (1 1/2")	1
16	CP14X3	Cotter Pin (1/4"x3")	1
17	716.07.02.00	Bottom Pivot Bolt	1

# SAFETY TRIP

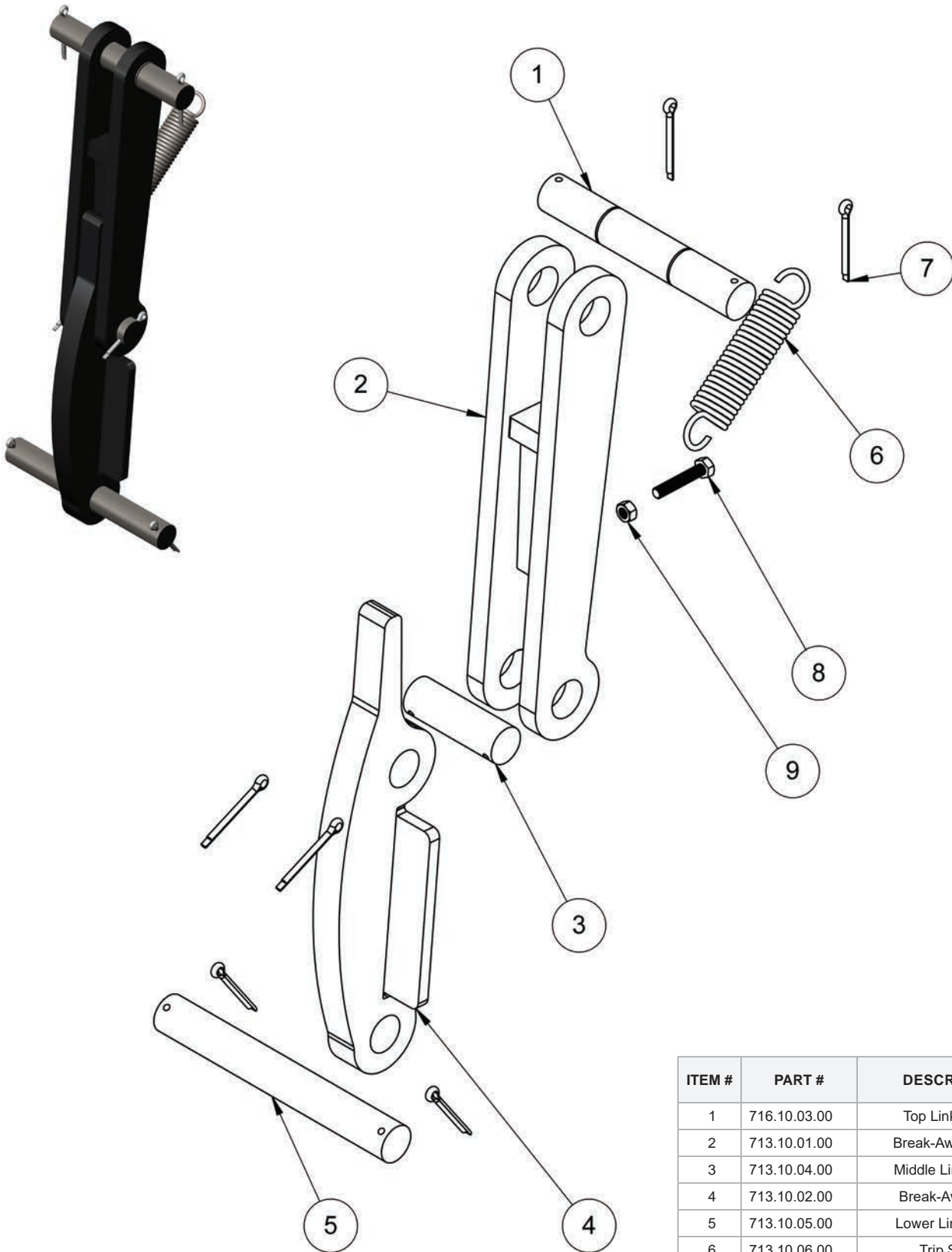

ITEM #	PART #	DESCRIPTION	QTY
1	716.10.03.00	Top Linkage Pin	1
2	713.10.01.00	Break-Away Swivel	1
3	713.10.04.00	Middle Linkage Pin	1
4	713.10.02.00	Break-Away Stop	1
5	713.10.05.00	Lower Linkage Pin	1
6	713.10.06.00	Trip Spring	1
7	CP316X2	Cotter Pin (3/16"x2")	6
8	NF8516134	Grade 8 Fine Thread Hex Bolt (3/16"x1 3/4")	1
9	NF8516-24	Grade 8 Fine Thread Hex Nut (3/16")	1

# COMPLETE PARTS LIST

PART #	DESCRIPTION	QTY	PAGE
<b>716.01.00.00</b>	<b>A-Frame</b>	<b>1</b>	<b>2</b>
716.01.01.00	A-Frame	1	3
713.01.02.00	Bump Stop	2	3
713.01.03.00	Hose Clamp Bracket	3	3
713.01.04.00	Cat. 4 Conversion Bushing	2	3
716.01.05.00	Cat. 3 Hitch Pin	2	3
716.01.07.00	Cat. 4 Top Link Pin	1	3
1.75_Lynch_Pin	Lynch Pin (1¾")	3	3
N12	Hex Nut (½")	3	3
NN34	Nylon Lock Nut (¾")	2	3
Round Locking Pin	Round Locking Pin	1	3
FIM_USA_Sticker	FIM USA Sticker	4	3
Innovator_716_Sticker	Innovator 716 Sticker	2	3
FIM_716_Sticker	FIM Logo Sticker	2	3
Grease_Sticker	Grease Daily Sticker	1	3
FIM_SN_Plate	Serial Number Plate	1	3
FIM_QC_Sticker	FIM Quality Control Sticker	1	3
<b>716.02.00.00</b>	<b>Boom</b>	<b>1</b>	<b>2</b>
716.02.01.00	Boom	1	4
716.02.05.00	Top Pivot Guide	1	4
716.02.04.00	Pivot Point Cap	1	4
713.02.06.00	Bottom Pivot Guide	1	4
713.02.08.00	Pivot Guide Washer	1	4
H1134	Hex Bolt (1"x1¼")	6	4
H34134	Hex Bolt (¾"x1¼")	1	4
H14	Hex Bolt (1"x4")	2	4
Grease_Sticker	Grease Daily Sticker	6	3
<b>716.03.00.00</b>	<b>7<sup>th</sup> Bottom Boom Extension</b>	<b>1</b>	<b>2</b>
713.03.00.00	7 <sup>th</sup> Bottom Boom Extension	1	5
Grease_Sticker	Grease Daily Sticker	1	5
820.03.00.00	7 <sup>th</sup> & 8 <sup>th</sup> Bottom Boom Extension (Optional)	1	5
<b>716.04.00.00</b>	<b>Hydraulics</b>	<b>1</b>	<b>2</b>
DBH-3520-WC	Plow Hydraulic Cylinder	1	6
8MB-9MJ90	Hydraulic Cylinder Adapter	2	6
713.04.04.00	Hydraulic Hose (240")	1	6
713.04.05.00	Hydraulic Hose (220")	1	6
8010-4	Hydraulic Tractor Coupler	2	6
<b>716.05.00.00</b>	<b>Front Gauge Wheel</b>	<b>2</b>	<b>2</b>
716.05.01.00	Front Gauge Wheel	2	7
16081	Mtd Wheel & Tire	2	7
<b>716.06.00.00</b>	<b>Rear Gauge Wheel</b>	<b>1</b>	<b>2</b>
713.06.01.00	Gauge Wheel Bracket	1	8
716.06.02.00	Gauge Wheel Tubing	1	8
716.06.03.00	Gauge Wheel Mount	1	8
713.06.04.00	Turnbuckle Pin Upper	1	8
713.06.05.00	Turnbuckle Pin Lower	1	8
713.06.06.00	Gauge Wheel Bracket Bolt	1	8
713.06.07.00	Turnbuckle	1	8
716.06.03.02	Pivot Point Cap	1	8
716.06.03.03	Pivot Washer	1	8
SN112	Slotted Nut (1½")	1	8
CP14X3	Cotter Pin (¼"x3")	3	8
16081	Mtd Wheel & Tire	1	8
H12112	Hex Bolt (½"x1½")	8	8
Grease_Sticker	Grease Daily Sticker	1	8
<b>716.07.00.00</b>	<b>Plow Bottom 1-4</b>	<b>4</b>	<b>2</b>
716.07.01.00	Plow Bottom	1	9

PART #	DESCRIPTION	QTY	PAGE
ASB101	Baker Shin Switch Plow	2	9
ASB103	Baker Landside Short	2	9
BW100	Baker Poly Wing Cover	1	9
SB100	Baker Share Switch Plow	1	9
P122	Plow Bolt (½"x2")	6	9
P12112	Plow Bolt (½"x1½")	20	9
FN12	Flange Nut (½")	26	9
SN112	Slotted Nut (1½")	1	9
CP14X3	Cotter Pin (¼"x3")	1	9
716.07.02.00	Bottom Pivot Bolt	1	9
<b>716.08.00.00</b>	<b>Plow Bottom 5-6</b>	<b>2</b>	<b>2</b>
716.07.01.00	Plow Bottom	1	10
ASB101	Baker Shin Switch Plow	2	10
BW100	Baker Poly Wing Cover	1	10
SB100	Baker Share Switch Plow	1	10
713.08.03.00	Long Outrigger Brace	1	10
ASB102	Baker Landside Long	2	10
713.09.01.00	Dual Outrigger Bracket (R)	1	10
713.09.02.00	Dual Outrigger Bracket (L)	1	10
P122	Plow Bolt (½"x2")	6	10
P12112	Plow Bolt (½"x1½")	22	10
FN12	Flange Nut (½")	30	10
P12212	Plow Bolt (½"x2½")	2	10
SN112	Slotted Nut (1½")	1	10
CP14X3	Cotter Pin (¼"x3")	1	10
H12112	Hex Bolt (½"x1½")	2	10
N12	Hex Nut (½")	2	10
716.07.02.00	Bottom Pivot Bolt	1	10
<b>716.09.00.00</b>	<b>Plow Bottom 7</b>	<b>1</b>	<b>2</b>
716.07.01.00	Plow Bottom	1	11
ASB101	Baker Shin Switch Plow	2	11
BW100	Baker Poly Wing Cover	1	11
SB100	Baker Share Switch Plow	1	11
713.08.03.00	Long Outrigger Brace	2	11
ASB102	Baker Landside Long	4	11
713.08.01.00	Single Outrigger Bracket (R)	1	11
713.08.02.00	Single Outrigger Bracket (L)	1	11
P12112	Plow Bolt (½"x1½")	28	11
FN12	Flange Nut (½")	36	11
P122	Plow Bolt (½"x2")	6	11
P12212	Plow Bolt (½"x2½")	2	11
H12112	Hex Bolt (½"x1½")	2	11
N12	Hex Nut (½")	2	11
SN112	Slotted Nut (1½")	1	11
CP14X3	Cotter Pin (¼"x3")	1	11
716.07.02.00	Bottom Pivot Bolt	1	11
<b>716.10.00.00</b>	<b>Safety Trip</b>	<b>7</b>	<b>2</b>
716.10.03.00	Top Linkage Pin	1	12
713.10.01.00	Break-Away Swivel	1	12
713.10.04.00	Middle Linkage Pin	1	12
713.10.02.00	Break-Away Stop	1	12
713.10.05.00	Lower Linkage Pin	1	12
713.10.06.00	Trip Spring	1	12
CP316X2	Cotter Pin (¾"x2")	6	12
NF8516134	Grade 8 Fine Thread Hex Bolt (¾"x1¼")	1	12
NF8516-24	Grade 8 Fine Thread Hex Nut (¾")	1	12



**FIM**

**432-758-0068**

P.O. Box 780 | 373 County Road 307 | Seminole, Texas 79360

[www.fimtx.com](http://www.fimtx.com)

